

Code No: 152AG

JAWAHARLAL NEHRU TECHNOLOGICAL UNIVERSITY HYDERABAD**B.Tech I Year II Semester Examinations, May - 2019****ENGINEERING GRAPHICS****(Common to EEE, IT)****Time: 3 hours****Max Marks: 75****Answer all five questions****All questions carry equal marks**

- 1.a) The foci of an ellipse are 90 mm apart and the minor axis is 65 mm long. Determine the length of major axis and draw the ellipse.
- b) The distance between two stations is 200 km and its equivalent distance on map measures 10 cm. Draw a diagonal scale to indicate 223 km and 135 km. [8+7]

OR

- 2.a) Construct an ellipse when the major axis is 120 mm and the distance between the foci is 108 mm. Determine the length of the minor axis.
- b) Construct a diagonal scale to read meters, decimeters and centimeters and long enough to measure up to 4 m. R.F of the scale is $1/20$. Mark on your scale a distance of 2.28 m. [8+7]

- 3.a) A point P is 20 mm below the HP and lies in the third quadrant. Its shortest distance from xy is 40 mm. Draw its projections.
- b) The projectors of the ends of a line AB are 5 cm apart. The end A is 2 cm above the HP and 3 cm in front of the VP. The end B is 1 cm below the HP and 4 cm behind the VP. Draw the projections of the line. [5+10]

OR

- 4.a) Draw the projections of a thin square plate ABCD of side 50 mm, parallel to VP when its edge AB is on the HP and 25mm in front of VP.
- b) ABC is a triangular plate having AB, BC and CA equal to 40 mm, 46 mm and 50 mm respectively. The side AB is parallel to HP, 10 mm above HP and makes 30° to VP. Draw its projections when plate is inclined at 45° to the HP and corner A 20 mm from VP. [5+10]

- 5.a) A pentagonal prism, side of base 25 mm and axis 50 mm long, rests with one of its base edges on HP such that the base containing that edge makes an angle of 30° to HP and its axis is parallel to VP. Draw its projections.
- b) Draw the top and front view of a cone of base diameter 46 mm and height 65 mm lying with one of its generators on HP. The axis is parallel to VP. [8+7]

OR

- 6.a) A hexagonal pyramid, base 25 mm side and axis 50 mm long has an edge of its base on the ground. Its axis is inclined at 30° to the ground and parallel to the VP. Draw its projections.
- b) Draw a cone, base 40 mm diameter and axis 50 mm long resting on the HP on its base. Axis is 25 mm away from V.P. [10+5]

7. A cone, base 50 mm diameter and axis 60 mm long, rests with its base on HP. A section plane perpendicular to VP and inclined at 45° to HP bisects the axis of the cone. Draw the development of lateral surface of the remaining portion of the cone. [15]

OR

8. A vertical chimney of 70 cm diameter joins a roof sloping at 35° with horizontal. The shortest portion over the roof is 32 cm. Obtain the shape of the sheet metal from the chimney that can be fabricated. [15]
9. Draw the isometric view of figure 1. All dimensions are in mm. [15]

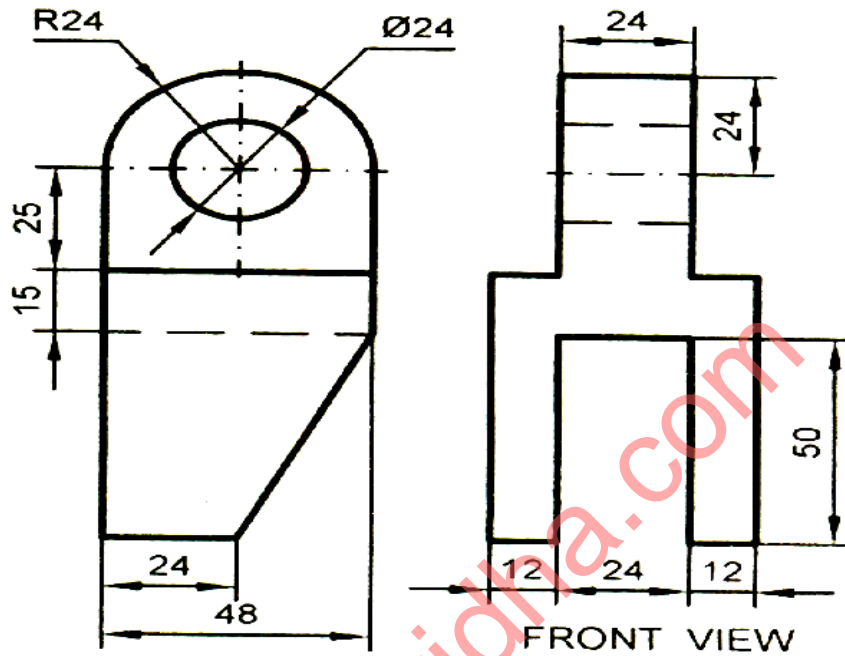

Figure: 1
OR

10. Draw the a) Front view b) Top view c) Right side view of the figure 2. All dimensions are in mm. [15]

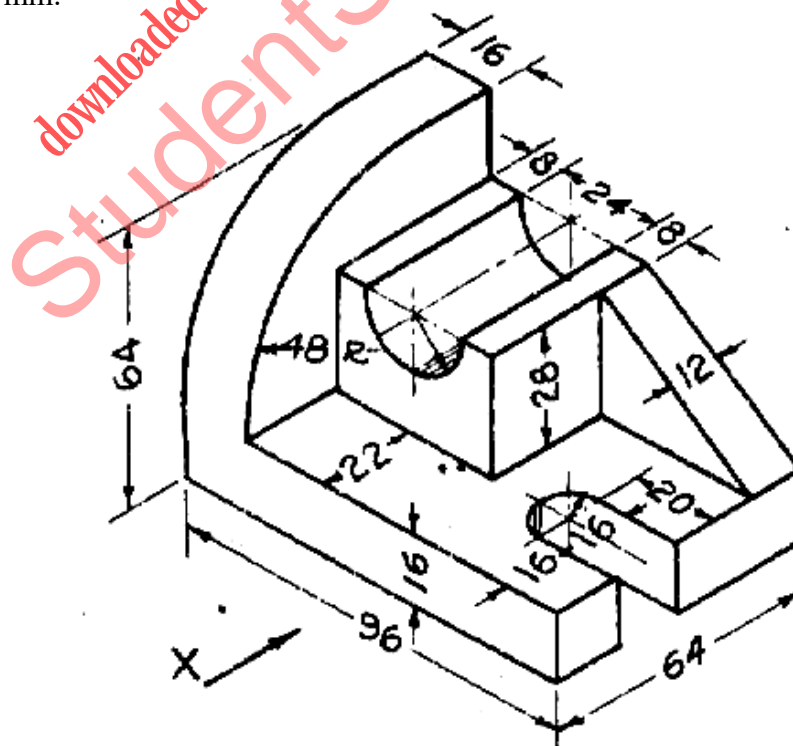

Figure: 2

---ooOoo---